



MODEL RSA

Project:
Tag:
Engineer:
Contractor:
Date:

Rectangular Sound Attenuators

1-Construction with 25mm flange

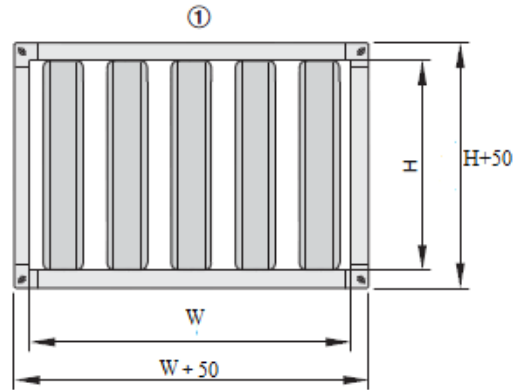
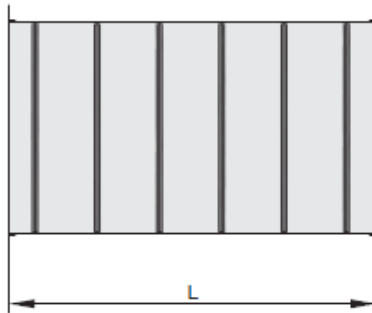

2-Construction with 35mm flange

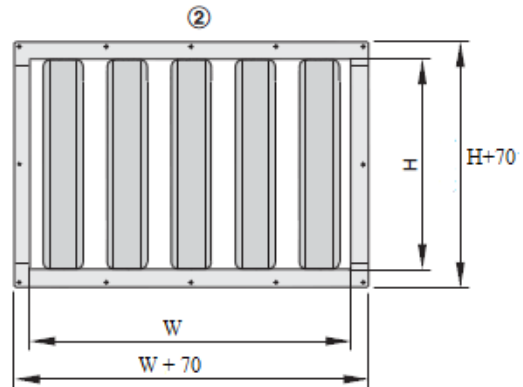
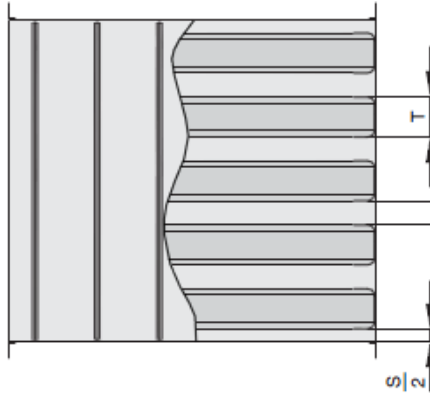

nominal length

* Any combination of these sizes

L	mm	500	750	1000	1250	1500
---	----	-----	-----	------	------	------

nominal height

* Any combination of these sizes

H	mm	300	600	900	1200	1500	1800
---	----	-----	-----	-----	------	------	------

Sound attenuator casing, nominal width

W	RSA-100			RSA-200		
	T	n	S	T	n	S
	mm	-	mm	mm	-	mm
200	100	1	100	-	-	-
400	100	2	100	200	1	200
600	100	2-4	50-200	200	2	100
800	100	3-5	60-167	200	2-3	67-200
1000	100	4-7	43-150	200	3-4	50-133
1200	100	4-8	50-200	200	3-5	40-200
1400	100	5-10	40-180	200	4-5	80-150
1600	100	6-11	46-200	200	4-7	57-200
1800	100	6-12	50-200	200	5-8	50-160
2000	100	7-14	43-186	200	5-8	50-200
2200	100	7-15	47-200	200	6-9	44-167
2400	100	8-16	50-200	200	6-10	40-200

As part of our continuous improvement program, we reserve the right to make further improvements without notice.

Date submitted: